



***Time Electronics***

**7095**

**Hydraulic Calibration Pump**

**700bar**

**User Manual**



# 1. Introduction

The 7095 Hydraulic calibration hand pump is designed for ease of use with a fully adjustable stroke control providing quick priming, easy pumping and a fast pressure generation up to 700 bar (10,000 psi), fine control of the desired set point pressure is achieved with use of the vernier control.

The pump has changeable built in filters to the output and gauge ports. The shatterproof reservoir and stainless steel construction ensure reliable leak free operation.

## Specification

<b>Output Range:</b>	0 to 700 bar (0 to 10,000psi)
<b>Gauge Port:</b>	3/8" BSP (blanking plug fitted)
<b>Process (UUT) Connection:</b>	1/4" BSP (Fitted Minimes TP)
<b>Reservoir Capacity:</b>	130mL
<b>Materials:</b>	Stainless steel fittings, polyurethane anodized aluminium housing, plastic/rubber handles, PTFE, nitrile o-rings.
<b>Weight:</b>	1.36kg.

## Contents

- 7095 pump
- Minimes/1/4" BSP high pressure hose
- 1/4" BSP blanking plug
- Selection of spare bonded washers, filters, washers and o-rings.
- Carry Case

# 2. Operational Notes

- Do not exceed 700bar (10,000 psi), the 7095's maximum pressure.
- Do not try to achieve 700bar by pump action alone.
- The filler cap incorporates a small breather valve, it is normal for a very small amount of media fluid to trickle out, especially if the pump is held horizontally.
- The 7095 comes with a 3/8" BSP gauge port fitted with a blanking plug and a 1/4" BSP output port fitted with a capped Minimes 1620 test point.
- Use only bonded washers (Dowty) to seal adaptors.
- Use only with distilled water or mineral based hydraulic oil.
- Two bonded washers are fitted to seal the output port.

*All Time Electronics' instruments are subject to continuous development and improvement and in consequence may incorporate minor detail changes from the information contained herein.*

### 3. Operation

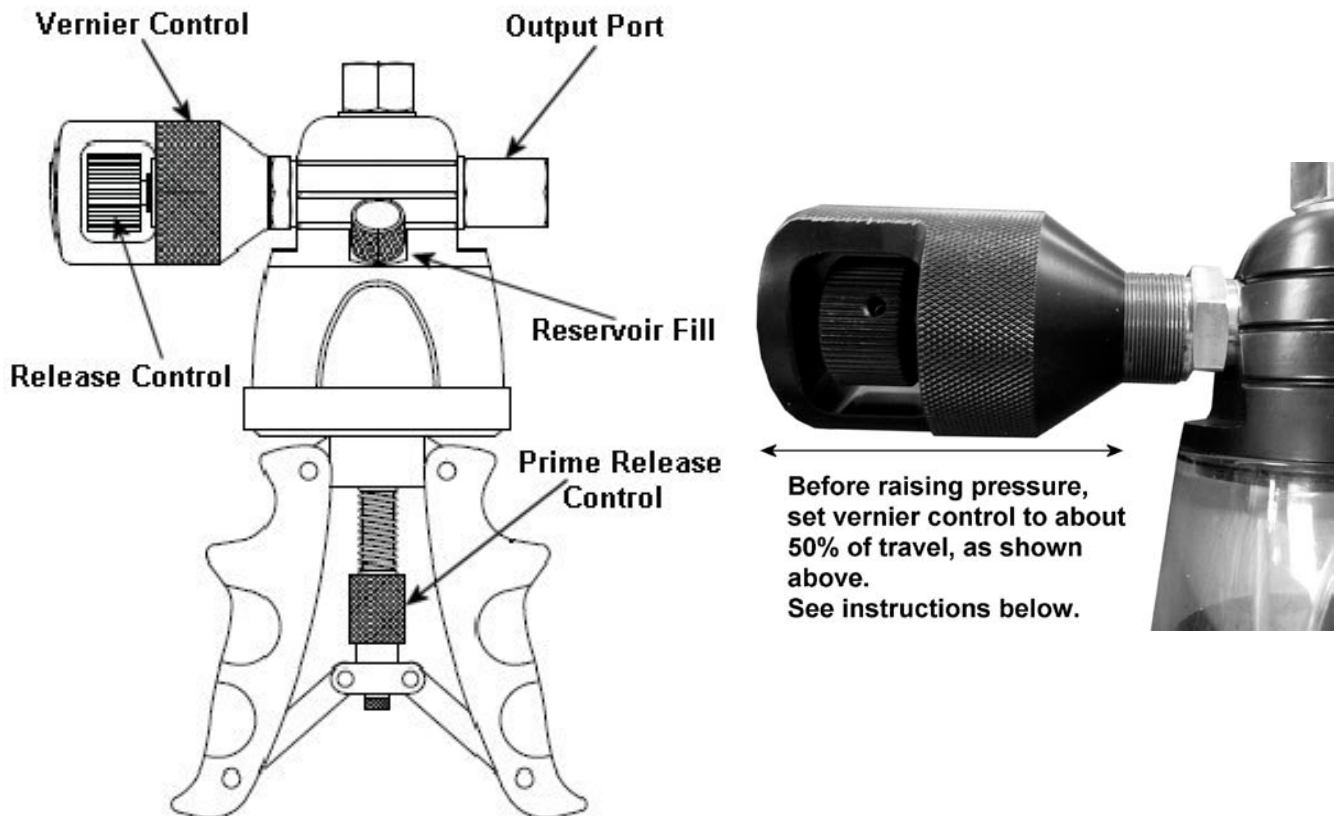

1. Remove the reservoir fill cap, and fill with an approved fluid to the required level (130 millilitres maximum). Refit the cap.
2. Connect the Minimess hose to the Minimess adaptor on the output port and connect to the instrument under test.
3. Connect the calibrator with a suitable adaptor to the 7095 via the top gauge port.
4. Set the vernier control to about half its travel and fully screw in the release control valve, no need to over tighten.
5. To prime the system, twist the knurled knob marked "Release" .Squeeze the handles together and release. Twist the knob once again. Repeat until the system is fully primed and a low pressure is indicated on either the UUT or on the calibrator. This feature can be engaged at any pressure.
6. **Be sure not to exceed the 700bar (10,000psi) maximum operating pressure indicated on the pump.** There is no pressure relief valve.Squeeze pump handles raising the pressure to about 50% of final required pressure. Screw in the vernier control to increase pressure to final set point, or screw out the vernier to decrease pressure to desired set point.
7. If the fluid level in the reservoir falls considerably during use, a partial vacuum may be created which could affect pump performance. To avoid this simply allow air to enter the reservoir by partly unscrewing the filler cap. If the system demands more fluid, remove cap and add more, do not over fill, the total amount in the system should not exceed the capacity of the reservoir.
8. For fast controlled decompression, unscrew the release control valve.

## 4. Guarantee & Servicing

### Guarantee Period

This unit is guaranteed against defects in materials and workmanship for a period of one year from its delivery to the customer.

During this period we will, subject to the instrument not being damaged due to maltreatment or overload, repair or replace it free of charge apart from shipping costs.

For repair under guarantee, the instrument serial number must always be quoted, together with details of the fault. The purchaser of the instrument must prepay all shipping charges. This guarantee is void if servicing or repair has been attempted by an unauthorized person or agent.

### Service and Calibration

Routine servicing and recalibration of your instrument is an essential part in the life of any calibration instrument. This will ensure that your instrument is performing to its specifications. All repairs are made using high grade and often specialised components to ensure on-going accuracy and performance. Our quality control (ISO9001) ensures the work is undertaken to the highest standards.

When an instrument is returned for repair any product enhancements, updates (hardware and software) will be done automatically.

### Returning Instruments

It is preferable to contact Time Electronics or their authorized agent to discuss any special paperwork (customer declarations etc) and shipping requirements. Always include information about the service required and your company details including a contact name, address, phone number and email address. Remember to include the name of the person you spoke to about the return.

When returning instruments, please ensure that they have been adequately packed, preferably in the original packing supplied. **We will not accept responsibility for units returned damaged.**

Send the instrument, shipping charges paid to:-

### **Time Electronics Ltd**

Botany Industrial Estate, Tonbridge, Kent, TN9 1RH

Tel: +44(0)1732 355993 Fax: +44(0)1732 770312

Email: [mail@TimeElectronics.co.uk](mailto:mail@TimeElectronics.co.uk)

Web Site: [www.TimeElectronics.com](http://www.TimeElectronics.com)